

EE CONDENSE

BOILER HOUSE VERSION OF
YEAR-ROUND MAXIMUM-CONDENSING
WATER HEATER



Over 95% GCV efficiency when
generating water at 60°C

Pure quality of hot water
- anodes not required

Long life with hard or soft water conditions



8BARS working pressure

95°C maximum working temperature

60°C to 95°C range of hot water available

Premix low NOX burner < 50mg /kWhr

A product of Great Britain, France, Germany
and Switzerland

Entirely made of 316L austenitic stainless steel
with 325 to 930litre water capacity

FOR TECHNICAL HELP/ADVICE Call 0161 621 5960
or email info@atlanticboilers.com

FOR FULL PRODUCT RANGE & LITERATURE
Visit www.atlanticboilers.com

EE CONDENSE

BOILER HOUSE VERSION OF YEAR-ROUND MAXIMUM-CONDENSING WATER HEATER

PERFORMANCE	EE40	EE60	EE70	EE80	EE150	EE300
Maximum heat input kW	40	60	70	80	150	300
Efficiency %GCV @ 60°C	> 95	>95	>95	>95	> 96	>95
Fuel used natural gas m ³ /Hr	4	6	7	8	15	30
Max working temperature °C	95	95	95	95	95	95
Max working pressure BAR	7	7	7	7	7	7
HOT WATER OUTPUT						
Water content litres	325	615	615	615	605	930
10 to 60°C litres hour	688	1032	1204	376	2580	5160
First 10minutes output @ 60°C	407	725	754	782	974	1697
First hour output @ 60°C	980	1585	1757	1929	3124	5997
Recovery 10°C to 60°C mins	28	36	31	27	14	11
DIMENSIONS						
Width mm	700	760	760	760	760	990
Depth mm	700	700	760	760	760	990
Height mm	1800	2250	2250	2250	2500	3060
Dry weight kgs	260	375	380	385	540	875

SPECIFICATION

A vertical insulated 316L stainless steel storage vessel

One or two serpentine stainless steel flue tubes with twin access points

Complete with an assembly of temperature & pressure relief valve,

Stainless combustion chamber, premix modulating burner,

A digital control panel with temperature limit & sensor control

Gas control bloc for 20mBAR supply

(by order - 30mBAR LPG control assembly)

Suitable for conventional flue, horizontal & vertical balanced flues

OPERATION

The burner has a pre-mix modulating, low NOx design.

The burner and a pre-mix fan are controlled digitally, working together,

And operate in a range 10% to 100% greatly reducing stop cycles and loss of heat by air-purging.

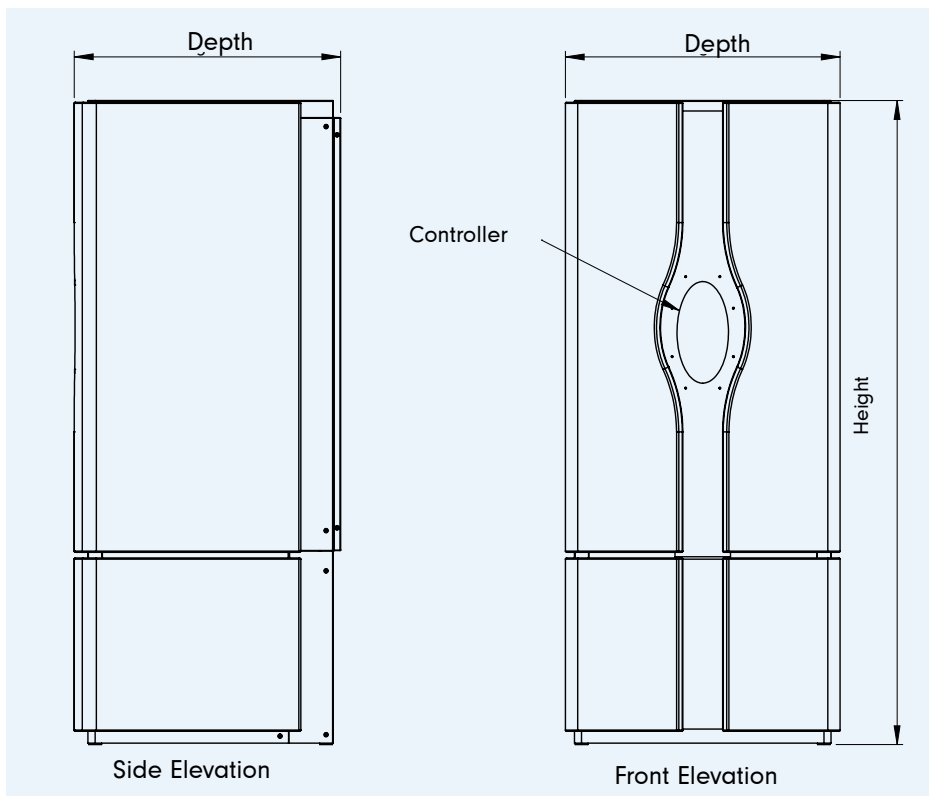

FOR TECHNICAL HELP/ADVICE Call 0161 621 5960
or email info@atlanticboilers.com

FOR FULL PRODUCT RANGE & LITERATURE
Visit www.atlanticboilers.com