

Thank you for using our KYUNG-DONG NAVIEN boiler.
To use this boiler in the proper way, be sure to read this manual fully before using it, and keep this manual with the warranty of the quality in a safe place.

CONTENTS

1. The structure and its description -----	2
2. How to install-----	5
3. Before using the boiler -----	9
4. How to use -----	11
5. Safety device-----	14
6. Everyday checking -----	15
7. How to replace parts-----	18
8. How to locate troubles and to solve -----	19
9. The specification -----	20
10. Electric wiring diagram -----	21
11. After sales service	

1. The structure and its description

■ The Structure of the boiler (Model No : 200NHC, 250NHC, 350NHC)

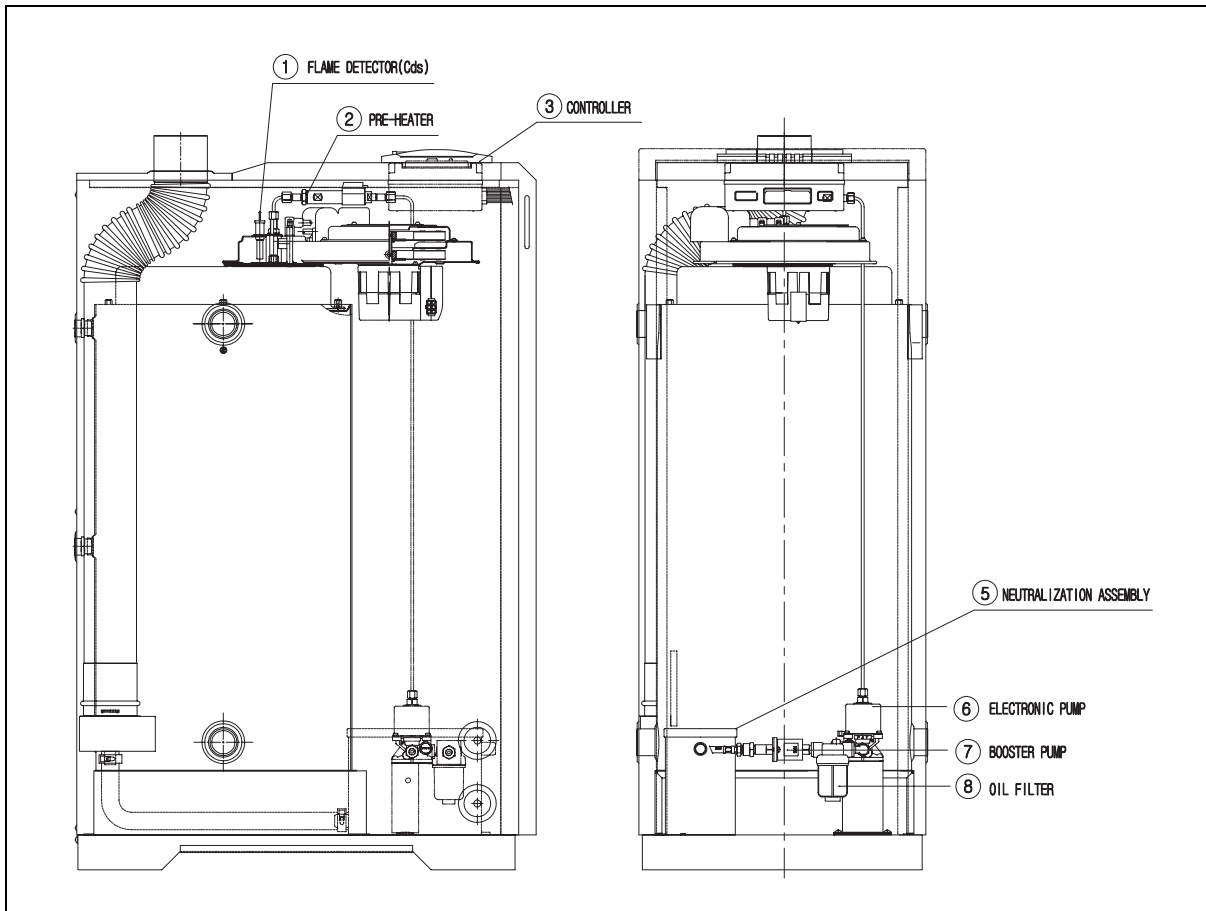

■ Operation and display panel (KDC-106M)

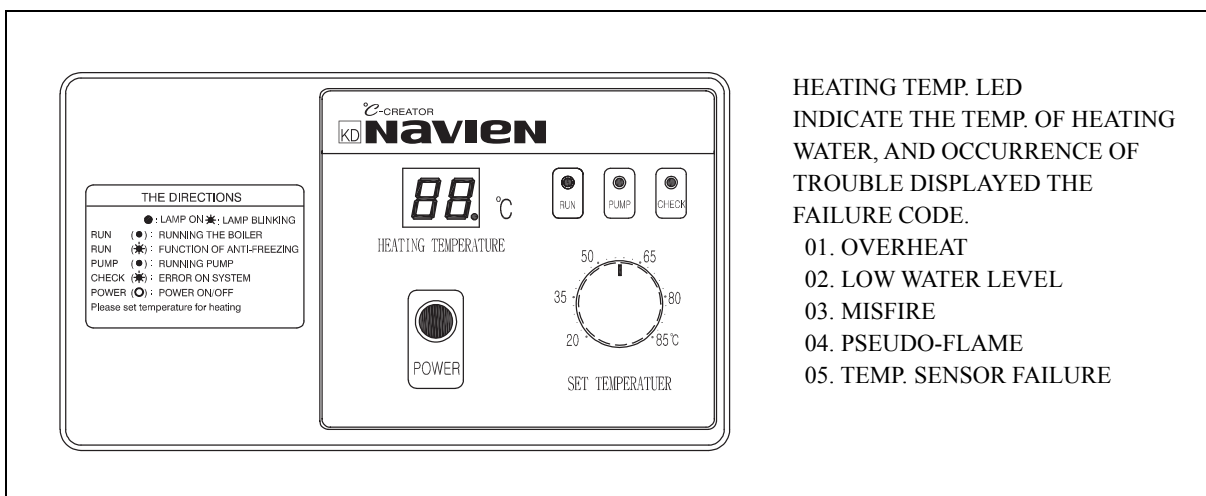

■ FR-9A Room controller(Model No : 200NHC, 250NHC, 350NHC)
 DESCRIPTIONS AND FUNCTION OF EACH COMPONENT (USE GUIDELINE)

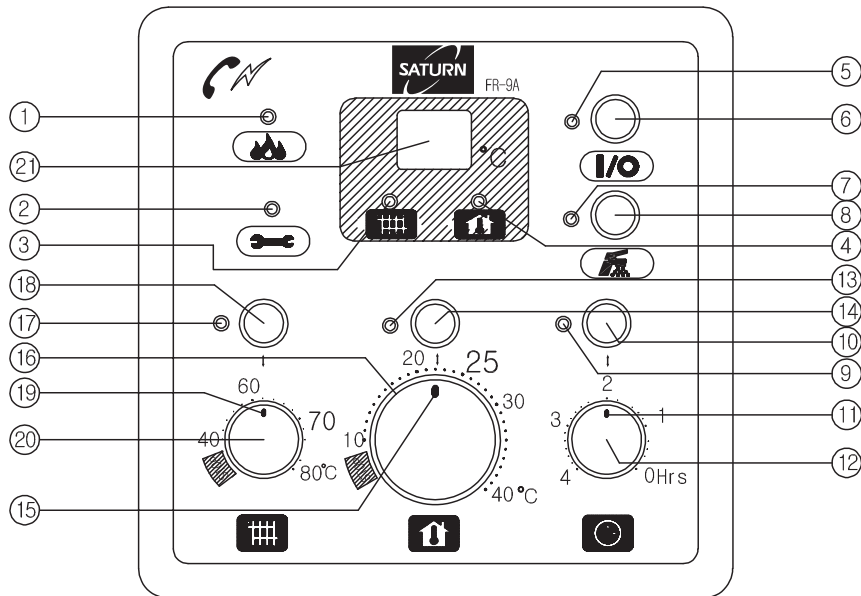

- | | |
|-----------------------------------|--|
| (1) RUN LAMP | (12) REPEAT TIMER CONTROLLER |
| (2) CHECK LAMP | (13) ROOM TEMP. LAMP |
| (3) HEATING WATER TEMP. LAMP | (14) ROOM TEMP. BUTTON |
| (4) ROOM TEMP. LAMP | (15) ROOM TEMP. INDICATION MARK |
| (5) POWER LAMP | (16) ROOM TEMP. CONTROLLER |
| (6) POWER S/W | (17) HEATING WATER TEMP. LAMP |
| (7) HOT WATER LAMP | (18) HEATING WATER TEMP. BUTTON |
| (8) HOT WATER S/W | (19) HEATING WATER TEMP. INDICATION MARK |
| (9) REPEAT TIMER LAMP | (20) HEATING WATER TEMP. CONTROLLER |
| (10) REPEAT TIMER BUTTON | (21) TEMP. LED |
| (11) REPEAT TIMER INDICATION MARK | |

1. Power : when you sue to turn the controller on/off (in the state of“off” controller. The anti-freezing device is run)
 - Press the power s/w(6), lamp(5) will on.
2. You can use hot water without heating room, in the temp. LED indicated room temperature on lighting lamp(4) on.
 - Press the hot water s/w(8), lamp(7) will on.
3. Heating related to heating water temp. If the boiler operated by heating water temp. On lighting the lamp(3) on (temp. range : 40-80°C)
 - Press the heating water temp. controller(18), lamp(17) will on. If the heating water indication mark(19) located on higher point than current heating water temp, the boiler operated but in the other way, the boiler not run
 - If you set the temp. Of heating water below 40, the boiler not run.
4. Heating related to room temp; if the boiler operated by room temp. controller(16). In-the temp. Led indicated current room temp. On lighting the lamp(4) on (temp. Range 10-40°C)
 - Press the room temp. controller(14). Lamp(13) will on, if the room indication mark(15) located on higher point than current room temp. The boiler operated but in the other way, the boiler not run.
 - If you set the room temp. below 10. The boiler not run.
5. Heating related to repeat timer : use the boiler according to repeat timer. In the temp. LED(21) indicated current room temp. On lighting lamp(4) on.
 - Press the repeat timer button(10), lamp(9) will on.
 - You can run the boiler according to the interval you set with timer.
 - You set the time interval
 - “0” : the boiler run continuously.
 - “1” : run 20min, then stop for 60min
 - “2” : run 20min, then stop for 120min
 - “3” : run 20min, then stop for 180min
 - “4” : run 20min, then stop for 240min
6. Run lamp. temp will on when the boiler operate.
7. Check lamp : indicate the trouble of boiler (misfire, low water level, overheating, etc.)
8. Temp. LED : indicate the temp. of heating water or room in norman, but in occurrence of trouble displayed the failure code.

01 : overheat	02 : low water level
03 : misfire	04 : pseudo-flame
05 : heating sensor failure	
9. Activation/suspension of boiler using telephone set

When you activate the boiler, it will operate at ‘high speed’ for 30 minutes, and will automatically switch to ‘out’ mode, and ‘operation lamp’ will light on during the operation. Using internal telephone set connected to the indoor temperature controller or outside telephone set (telephone or mobile phone), you can activate or suspend operation of the boiler remotely, by presetting the number of phone rings.

 - When using outside telephone (telephone set or mobile phone), call the phone, When the call is connected to the boiler after ringing the preset number of times, you will hear a ‘beep’ sound. Then, manipulate the buttons as described below.
 - When using the telephone connected to the indoor temperature controller, hold the handset, and manipulate the buttons as described below:

- Manipulation of buttons -

- 1) When activation the boiler [Press“#” button 3 times] : If you hear ‘beep-beep’ sound after pressing the “#” button three times, hang up the phone.
- 2) When suspending the boiler [Press“*” button 3times] : If you hear ‘beep-beep-beep’ sound after pressing the “*” button three times, hang up the phone.
- 3) When altering the number of ringing [Press “0” button 3 times] :
 - If you hear ‘beep-beep-beep-beep’ sound after pressing “0” button three times, press a button you select out of 5,6,7,8,9 and 0 three times.
 - When you hear ‘beep-beep-beep-beep-beep’ sound shortly after, hang up the phone.
- 4) Caution
 - 4-1) If you don’t press any button for 10seconds or longer after pressing ‘#’ or ‘*’ button, the telephone will automatically hang up.
 - 4-2) Make sure to hang up the phone after hearing activation signal(‘beep-beep’ or suspension signal(‘beep-beep-beep’)
 - 4-3) When you use a mobile phone, use it where transmission sensitivity is stable.
 - 4-4) If you don’t hear the ‘beep’ sound while using ROOMCON, manipulate it again slowly.

2. How to install

■ Choosing of the installation place

- For the place to install the boiler, choose the place possible to do the accompanying works, such as water supply works or electric works.
- For the place to install, choose the place conformed to the installation standards of the boiler and the construction act of the code of each city or municipality
- Install the boiler in the place as wide as possible for the maintenance and the fire prevention.
- Install the boiler in the place convenient for controlling and manipulation of the temperature.
- If there is no electric outlet in the proper position, do wiring by requesting to a company designated by the electric power company.
- Around the installation place, there must be no place which stores and treats the combustibles and the inflammables.
- There should be equipped drainage in the installing spot.

■ The diagram of the standard piping : Expansion tank install type (Model No. : 200NHC, 250NHC, 350NHC)

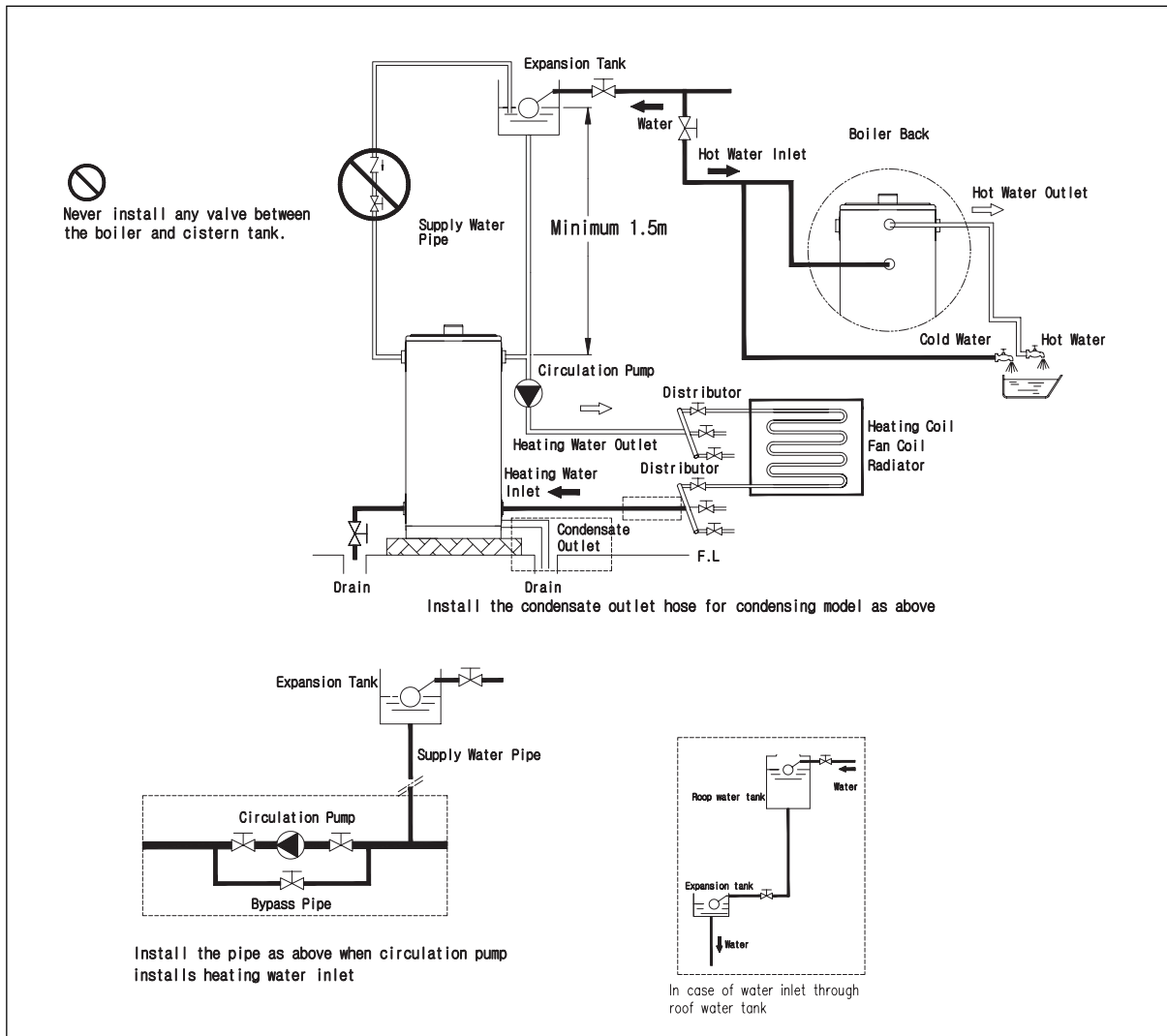

<Sealed cistern tank>

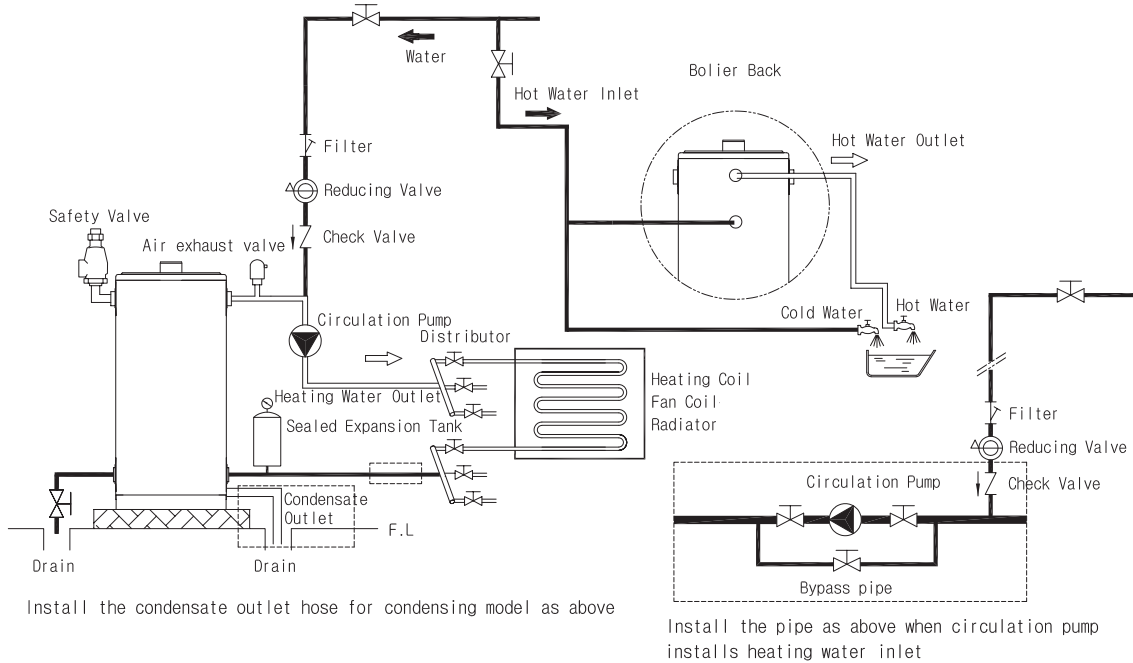

■ Precautions

- ① The distributor on the return water distributor side should be placed lower than the heating inlet.
- ② Connection should be made by installing a safety valve with 3.5kgf/cm^2 or lower opening the discharge piping to the cistern tank.
- ③ The maximum operation pressure is 3.5kgf/cm^2 . Do not supply water at a higher pressure or directly connect the water pipe having the pressure higher than.
- ④ Overflow of water during the heating to the cistern tank means short tank capacity. Exchange it with a larger one.
- ⑤ Backflow of water during the running or stopping of the circulation pump to the cistern tank is caused by too much air in the pipe. Remove air by opening valves on the distributor, one at a time, while running the circulation pump.
- ⑥ Evaporation at the cistern tank means failure in the system. Contact your representative to receive the check.
- ⑦ Never install any valve between the boiler and the cistern tank.
- ⑧ We will not be liable for any defect or breakdown caused by the failure to comply with the above precautions.

■ The example of a standard installation

Flue Work of Forced Exhaust(FE)

- It is recommend that the length of flue shall be less than 5 miters and the flexuosity shall be less than 2 point.(Except for the flexuosity at the end of the flue)
- It is recommend that use the flue fitting in the connection caliber.
- Be careful not to narrow down the flue. And please, maximize the radius of flexuosity when to work.
- It is recommend that keeping the flue warm by using the noninflammable insulation.

■ Condensing boiler model : KDB-130/170/200/250/350NHC

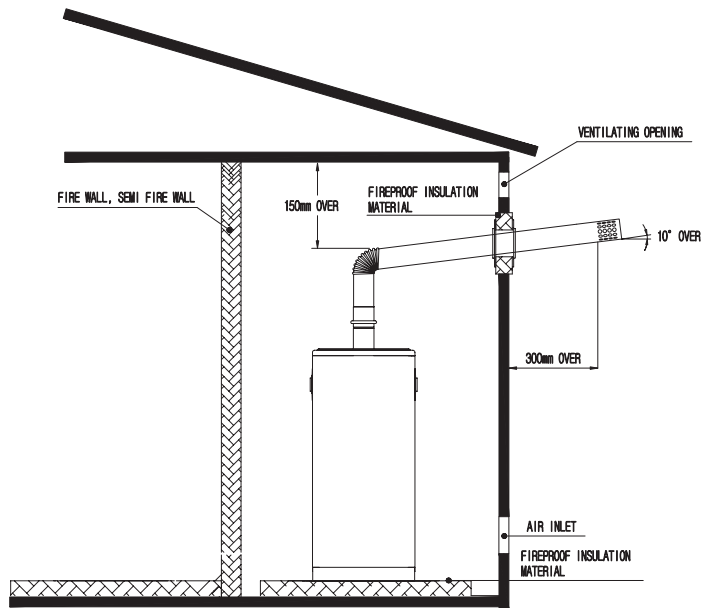

- When installing the flue, an angle of the flue shall be less than 10 degrees. Because the generated condensate in the flue is exhausted through the inside.
- If the angle of the flue should make more than 10 degrees, the rain will come into the inside of the boiler.
- Material of flue must be used stainless steel or heat-corrosion resisting metal.

⚠ Caution

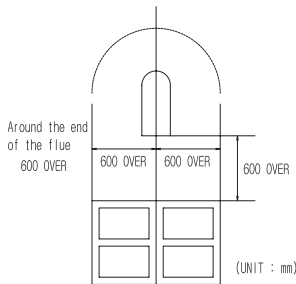

It is imperative that there are no windows around the end of the flue within 600mm.

- If the waste gas should come into the room, you will suffer from the waste gas poisoning.

■ Condensate Drainage

1. Condensate is produced when condensing boiler is running and should be piped to the drainage system.
2. Link the drain hose with the outlet of neutralization system located the bottom of boiler and then, surely, connect the end of hose to a sink hole or ditch directly.
3. In case of using other drain hose which is not installed originally, it must be plastic and its inside diameter should be more than $\Phi 13$
4. Please make sure that the neutralizer in the boiler should be filled with water, otherwise it must be filled.
5. Condensate never be allowed for drinking or washing
6. Avoid from any frozen on the drain hose of N.W, insulation must be followed by installing the hose.
(The additional device with anti-freeze function might be necessary for any sites are possibly exposed at freezing temperature.)

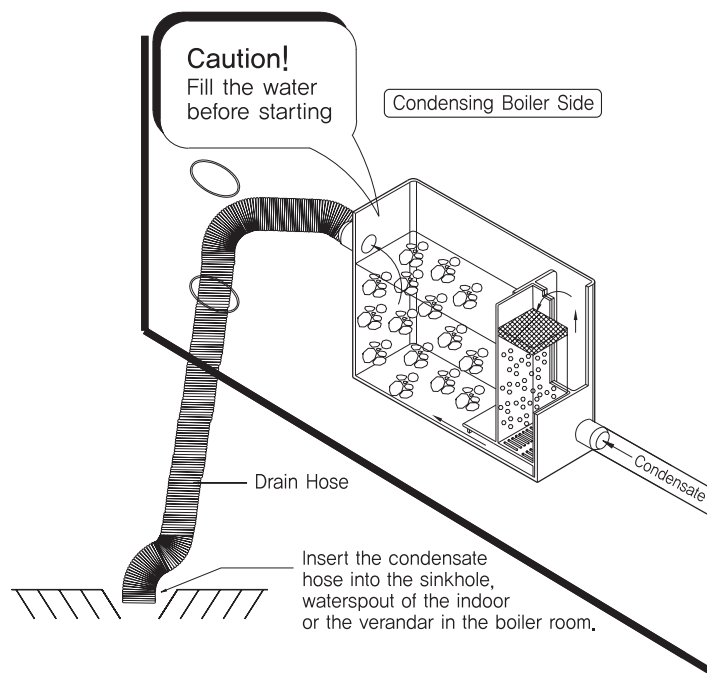

3. Before using the boiler

Fuel

- It is essential to use only kerosene or light oil. (Don't use gasoline, alcohol)
- It is better to use kerosene when the temperature goes down below -5°C
- In winter, don't use the light-oil for summer.

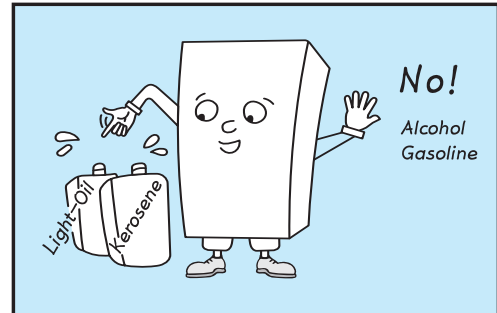

- Store in the place where there is no effect of oil, fire, rain, and keep out of the sun.
- Pay attention that water or dust may not get in on time of feeding oil. (Water or dust may cause the combustion failure or shorten the boiler span.)
- Wipe off the oil spilled.
- Close the lid of the oil inlet without fail.



- Feed oil after turning the power off and locking the tank valve.

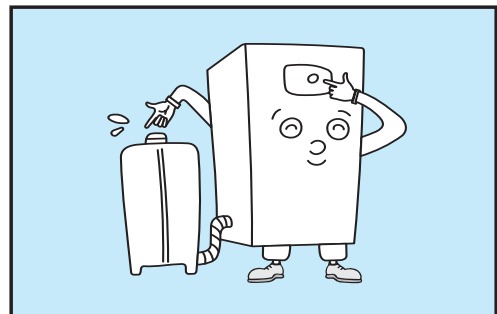

Checking points before starting up

- Check out if or not oil leaks in the connecting part of the oil pipe.

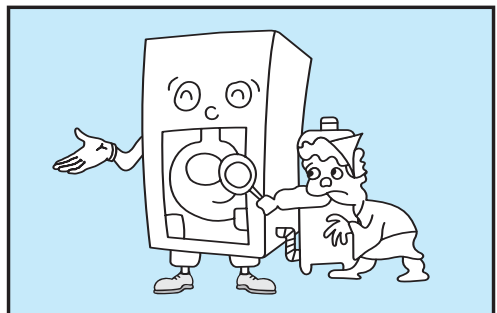

- Check out that there is enough water in the body of the boiler without failure.
- Expansion tank type-Check out if there is water in the Expansion tank, and in case that there is no water, please fill water in the body of the boiler.
- Open Expansion Tank type-check out if there is water in the expansion tank, and in case that there is no water, press the power button. Then, 'Low Water Level' lamp turns on and water is supplied automatically.

Notes when using

- Put the surroundings of the boiler in order and don't put the flammables near the boiler.

- Check out whether the ignition and the combustion is normal.
(Checking through the flame inspection window)
- When the boiler is going to be not in use for a long time, cut off the power.
(Don't pull out the power cord when there is a danger of freezing)
- If you pull out the power plug on time of thunder and lightening, you can prevent the damage on the boiler by the falling of the thunderbolts.

- Be careful not to get burned due to the high temperature of the exhaust/inhale pipe(exhaust pipe).
- In case of emergency such as you may feel the abnormality of the boiler. cut off the power.
- Don't use the hot water for food.

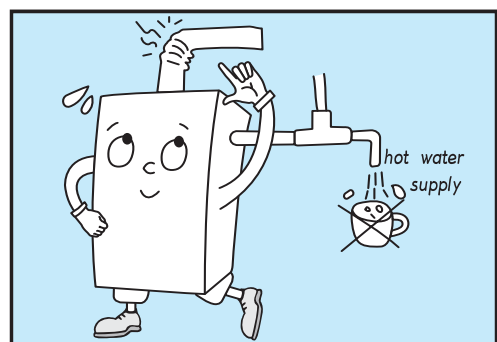
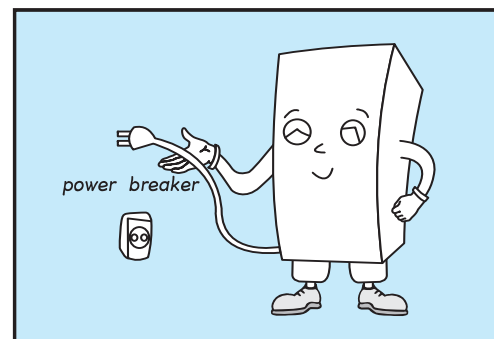
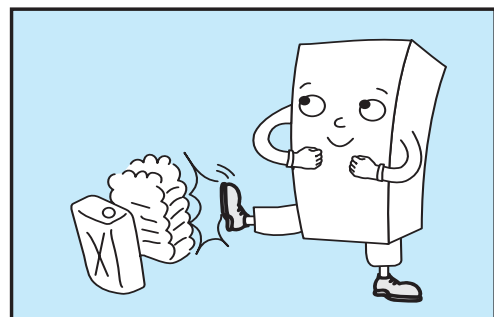
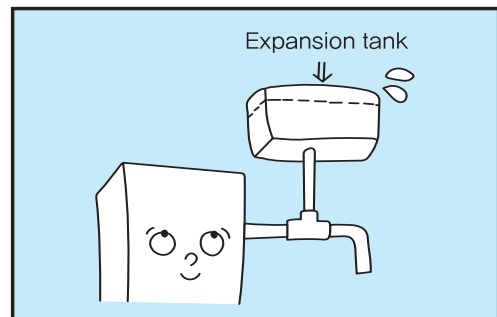

4. How to use

How to exhaust

- Be careful that the oil tank may not run out of oil completely.

In that case, even though oil is supplied, air may get in. As a result, ignition failure or operation failure may occur.

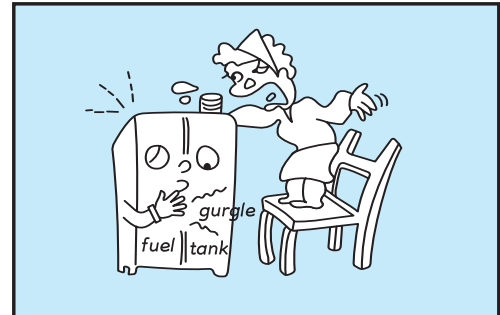

- Untighten the screw for exhaust in the oil filter by a screwdriver, the air goes out. When oil flows out, please tighten it.

(This is possible only in case that the oil tank is above the oil filter)

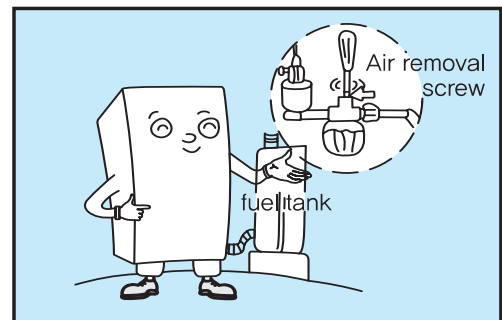

- If the oil tank is below the oil filter or the air flows out enough like the above, lock the screw for exhaust and remove the air with the exhaust valve.

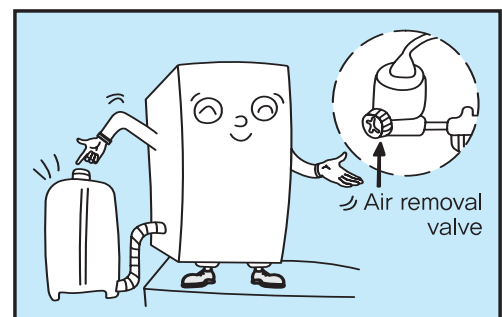

- In such case, open the exhaust valve turn the power on to operate the boiler. After about 6-7seconds, the electronic pump exhaust the air off with noise, and "CHECK" lamp on, the boiler stops.

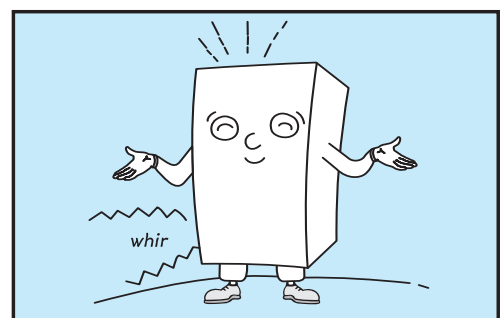

- Now press the power button on the panel repeatedly, and the oil flows out. Lock the valve and press the power button again, and the boiler gets ignited.
- In case that after removing air completely, the ignition has failed repeatedly about three times, contact the sales agency or the commercial agency.

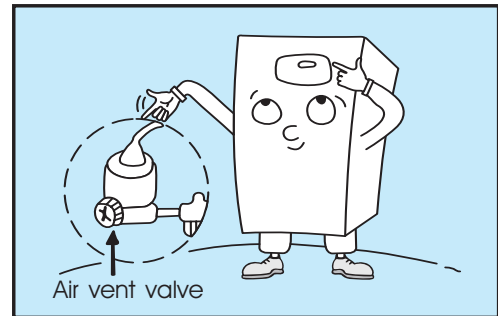

Preparation and checking before starting to operate

- Open the drain valve, and check out whether there is water in.
- Check out whether the pipes are filled with water.

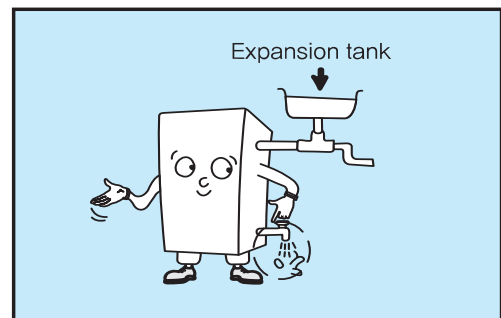

- Check out that the boiler is grounded to earth. (Don't ground to the gas pipe or a lightning conductor)

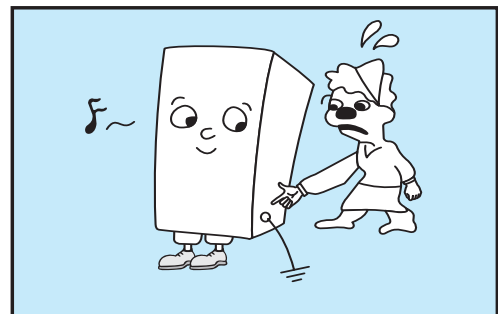

- Plug the power plug in the outlet. (Checking if the outlet power is 220V)
- Press the power button, and check out if "RUN" lamp turns on a little later.

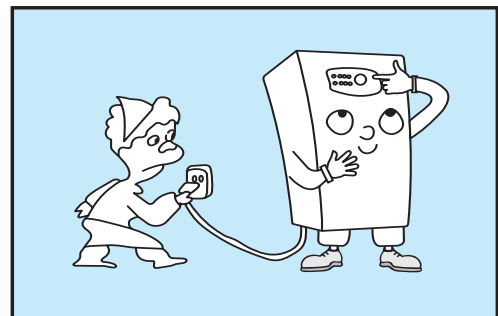

How to use

- Open the window door of the Operation and Display Panel and set the thermostat to the position you like.

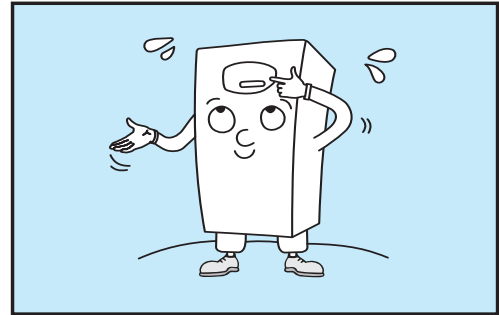

- Pressing the power button starts fan motor. And the boiler gets started, turning the “COMBUSTION” lamp on.

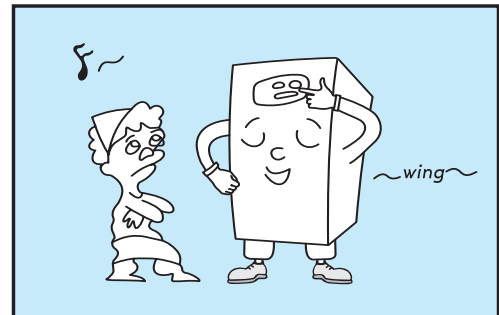

- If ignition fails and the operation stops, “check” lamp turns on. In this case, press the power button on the panel.
- In case that the ignition fails with pressing the power button four or five times, contact the sales agency or the commercial agency.

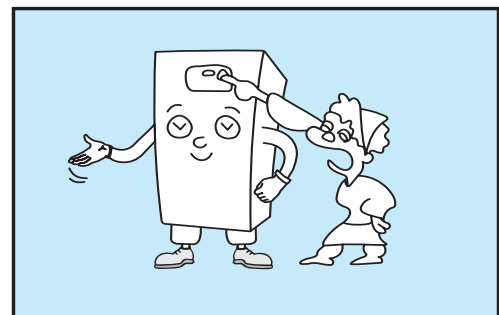

5. Safety device

Combustion safety device

- When it doesn't light even with the power button "ON" or it gets extinguished due to running out of oil, the FLAME Detector(CdS) gets to work and stops the operation.

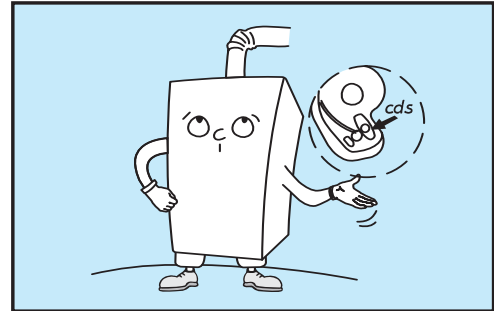

Low water level blocking device

- If water is insufficient in the boiler, it interrupts the operation of the boiler with the power cut off. When water refills, the boiler starts again automatically.

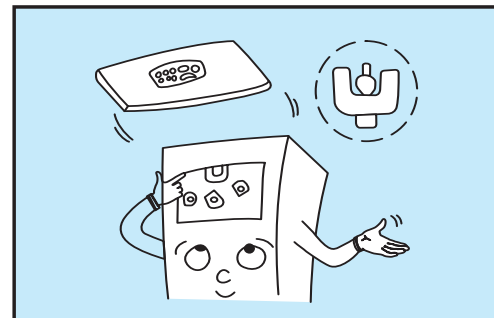

Overheating preventer

- If the temperature of the boiler rises up too high, it is dangerous. So, in such case, this device cut off the power automatically.
- When the overheating preventer gets to operated the combustion stops and "CHECK" lamp turn on.
- If the overhead temperature is fall "CHECK" lamp turn off and "RUN" lamp turning on automatically.
- If the operation stop is repeated again, contact the sales agency or the commercial agency.

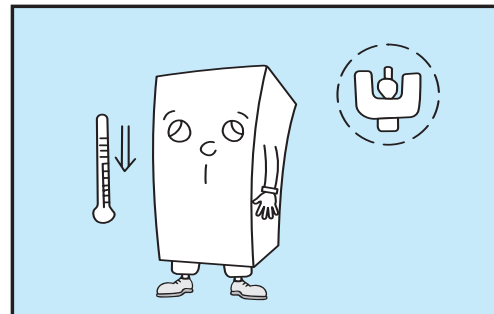

Freezing preventer

- During the hard winter, the circulation pump or the burner operates automatically to prevent the heating circuit from freezing. In winter, keep on plugging in the power cord and turning the power button "ON".(the insulation state of the pipes must be normal)

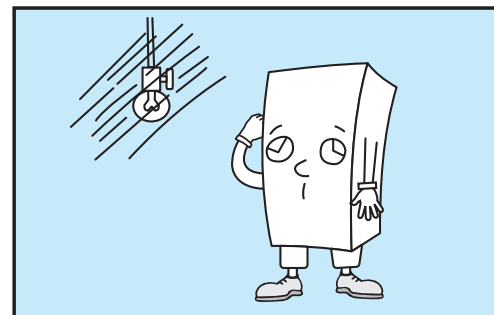

Safety device on power-failure

- If the power gets off, oil gets blocked automatically and the combustion stops.

6. Everyday Checking

Points to be checked once or more a year

- Check out whether the combustibles is near.
- Keep cleaning all the time and don't let the dust accumulated.
- Check out whether oil leaks from, is stacked on, or soaks into the oil tank, oil pipes, the body of the boiler, etc.
- Check out whether there is any water leakage from the body of the boiler and the pipes.
- Open the drain plug of the oil tank regularly and remove water.

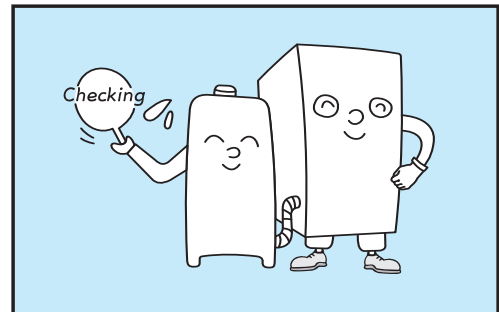
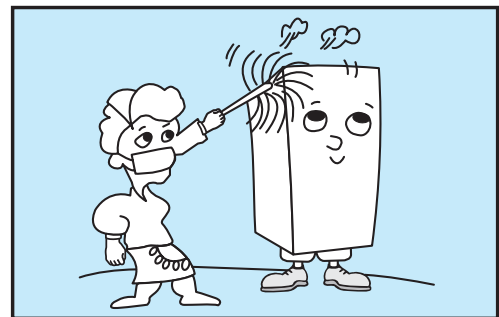
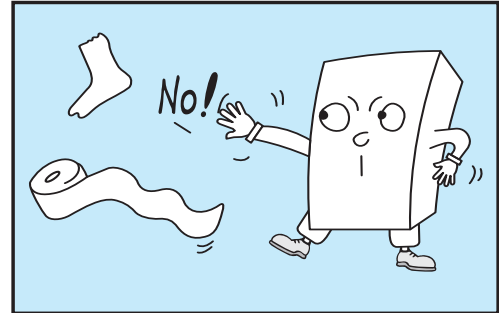

Cleaning of boiler

- Much soot accumulated inside the boiler will reduce the life and efficiency.
At least once a year, clean the boiler inside.



Cleaning the oil filter

- In case that the oil filter gets dirty, stop operating, lock the oil valve, and remove dust or rust accumulated below the oil cup.
 - Detach the oil cup by rotating right and left.
 - Pull down the filter.
-
- Wash the filter and the inside of the oil cup with clean kerosene and light oil.

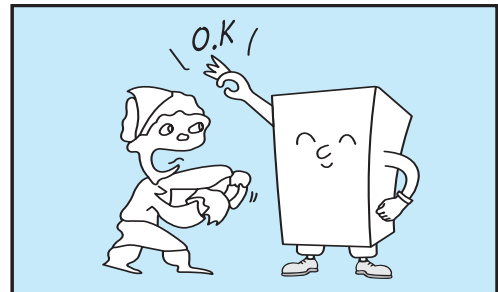
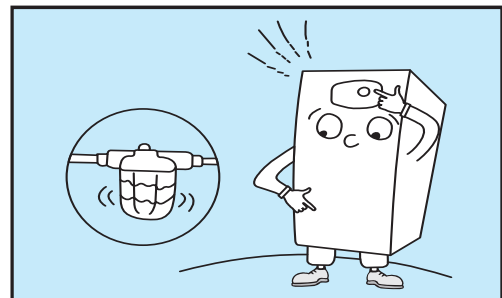

Cleaning the oil tank

- Water may get mired in during feeding oil or get accumulated naturally during the long period in the oil tank. In this case, drain water off through the drain plug in the oil tank, and when oil starts to get out, lock it.



Cleaning the flame detector

- If the light-receiving surface(sensing surface) gets darkened with soot, the bad sensitivity cause the wrong automatic operation.

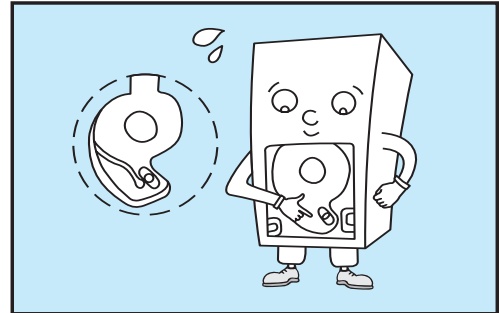

- You can pull out the flame detector(black) which is attached in the lower part of the burner.

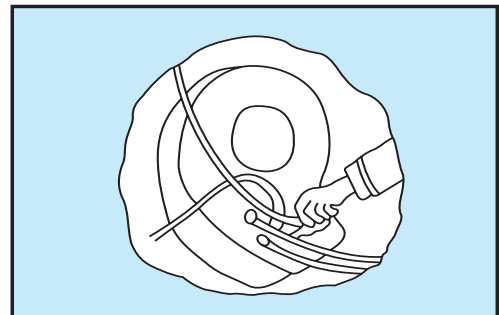

- Wipe the glassy surface of the flame detector with a scrap and fix it in its position.

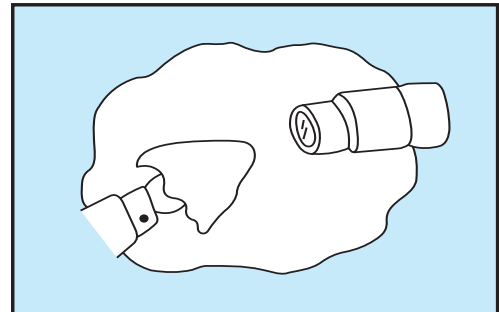

Checking the exhaust pipe

- At least once a year, check for any loose joints in the discharge(piping and flue), clogging in flue, corrosion or leak. If any abnormality is found, contact out sales agency for checking up.(blocking pipes or holes, and so on)

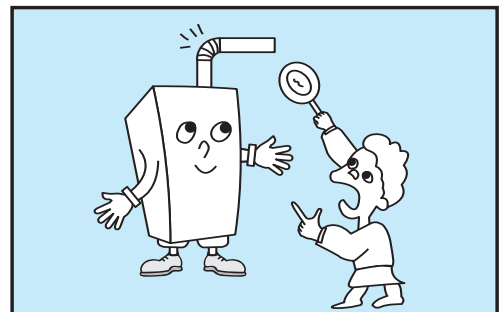

7. How to replace the parts

- There is no parts which gets wear in a short period, but when the replacement of the parts is needed, consult to out sales agency or commercial agency.

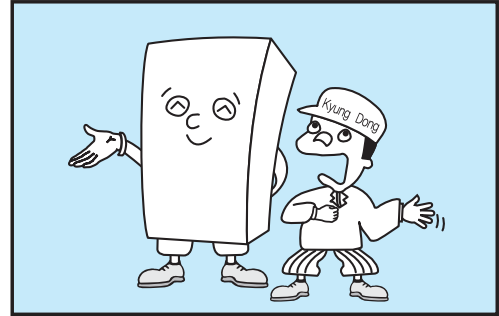

- For the repair of the boiler, request to our sales agency or commercial agency, or to the A/S center.

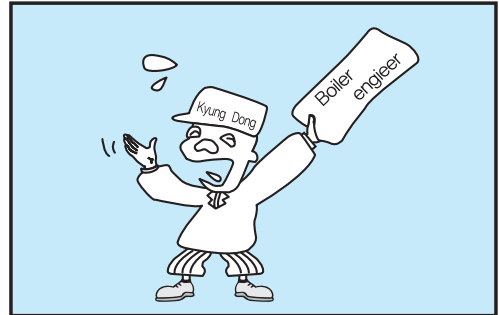

- Repairing the boiler by a man without qualification cause another trouble, so never do that.

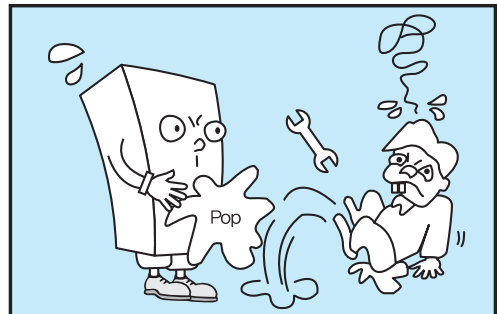

8. How to locate troubles and solve

Happening	Cause	Solution methods
1. Even with pressing the power button, the motor doesn't work	<ol style="list-style-type: none"> 1. The temperature in the boiler is above the set temperature. 2. The room controller is off. 3. Others. 	<ol style="list-style-type: none"> 1. This is not a trouble. When the temperature of the boiler goes down, get restarted. 2. Set the room controller to the operation condition. 3. Contact the sales agency or commercial agency.
2. The motor rotates, but the boiler doesn't ignite.	<ol style="list-style-type: none"> 1. The oil valve is locked. 2. There is no oil in the tank. 3. There is air in pipes. 4. The oil filter is locked. 5. Others. 	<ol style="list-style-type: none"> 1. Open the valve. 2. Supply oil. 3. Drain off air. 4. Clean the boiler. 5. Contact the sales agency or commercial agency.
3. The boiler ignites, but immediately stops.	<ol style="list-style-type: none"> 1. The oil in the oil tank is insufficient. 2. The flame detector(CdS) cannot sense. 3. The oil filter is locked. 4. There is mixed impure materials in the oil. 5. Others. 	<ol style="list-style-type: none"> 1. Supply oil more. 2. Clean the flame detector. 3. Clean the oil filter. 4. Replace the oil with good oil. 5. Contact the sales agency or commercial agency.
4. The electronic pump makes big noise.	<ol style="list-style-type: none"> 1. The oil filter is locked. 2. There is air in pipes. 3. Others. 	<ol style="list-style-type: none"> 1. Clean the oil filter. 2. Drain off air. 3. Contact the sales agency or commercial agency.
5. On igniting, it backfires.	<ol style="list-style-type: none"> 1. The wind flow back in the exhaust pipe. 2. The ignition device is bad. 3. Others. 	<ol style="list-style-type: none"> 1. Contact the sales agency or commercial agency. 2. " 3. "
6. The abnormal noise of the combustion happens.	<ol style="list-style-type: none"> 1. The air for combustion is excessive. 2. The amount of oil feed is excessive. 3. Others. 	<ol style="list-style-type: none"> 1. Contact the sales agency or commercial agency. 2. " 3. "
7. Smoke and soot occurs.	<ol style="list-style-type: none"> 1. The oil is bad or has impure materials. 2. The air for combustion is short. 3. Others. 	<ol style="list-style-type: none"> 1. Replace the oil. 2. Contact the sales agency or commercial agency. 3. "
8. Others.	<ol style="list-style-type: none"> 1. The fuel pipes leaks. 2. The water pipes leaks. 	<ol style="list-style-type: none"> 1. Contact the sales agency or commercial agency. 2. "

※ Please contact your local shop and distributor for other unclear matters.

9. The specification

CONDENSING OIL BOILER					
ITEM	UNIT	MODEL	KDB-200NHC	KDB-250NHC	KDB-350NHC
		HEAT OUTPUT	CONDENSING	kcal/h	21,500
(KJ/h)	(90,016)			(108,857)	(146,538)
NORMAL	kcal/h		20,500	25,500	32,500
	(KJ/h)		(85,829)	(106,763)	(136,071)
HOT WATER OUTPUT		kcal/h	20,500	25,500	32,500
		(KJ/h)	(85,829)	(106,763)	(136,071)
FOR USE			HEATING AND HOT WATER		
FUEL			KEROSENE, LIGHT-OIL		
ROOM SIZE		m ²	Less than 132	Less than 165	Less than 234
MAXIMUM WORKING PRESSURE		kgf/cm ²	3.5		
		(kPa)	(343)		
HEAT TRANSFERING SIZE		m ²	1.60	2.08	2.40
FUEL CONSUMPTION		ℓ/h	2.52	3.12	4.03
TYPE OF AIR/EXHAUST GAS			FE		
HEATING EFFICIENCY	CONDENSING	%	101	101	101
	NORMAL	%	95	95	95
HOT WATER EFFICIENCY		%	95	95	95
ELECTRICITY CONSUMPTION	COMBUSTION	W	143	150	199
POWER		V, Hz	220V, 50Hz		
WATER STORAGE CAPACITY		ℓ	34.0	41.0	48
EXTERNAL SIZE		W×L×H	410×665×1,031	444×706×1,051	444×706×1,186
		(mm)			
WEIGHT		kg	59	64	72.0
PIPING	HEATING CONNECTION	A	25		
	HOT WATER CONNECTION	A	15		
DIAMETER OF FLUE		φ mm	EXHAUST : 75		

※ The specification in this operating manual can be changed for improvement without prior notice.

10. Electric wiring diagram

■ MODEL NO : KDB-200NHC, 250NHC, 350NHC

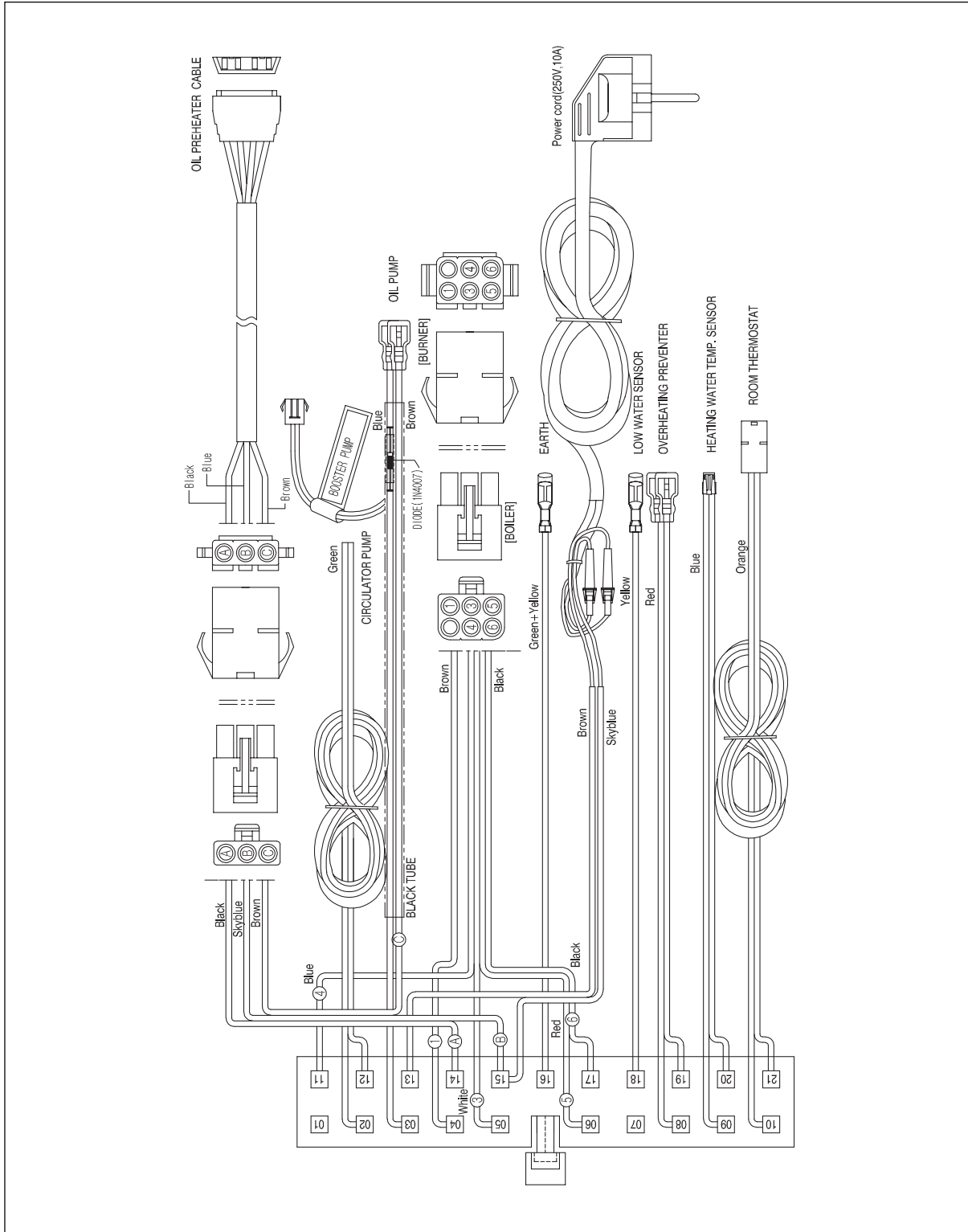

WARRANTY FOR QUALITY

Thank you for purchasing a KYUNG-DONG Navien. This product has passed the thorough quality control and strict test by the KYUNG-DONG technical team. If some defects of the production process or spontaneous troubles occur within the warranty period, Contact our sales agency where you purchased if or our service center with this warranty. We are ready to repair it without any charge.

※ The warranty period of a KYUNG-DONG boiler is 1 years since the purchase date.

PRODUCT NAME		PURCHASE DATE	DATE	REPAIRED ITEMS	NAME OF ENGINEER	CHECK
MODEL NAME						
LOT NUMBER						
CUSTOMER	ADDRESS					
	NAME	(T)				
SALES AGENCY	ADDRESS					
	NAME	(T)				

※ Please check out there is an item which is not filled.

※ This KYUNG-DONG NAVIEN WARRANTY FOR QUALITY is not re-issued. Please keep it in the safe place.

MEMO

MEMO